

CHINESE MOBILE PAYMENT LANDSCAPE: A STIMULUS ORGANISM RESPONSE MODEL EXAMINING PERCEIVED VALUE, SATISFACTION, AND INFLUENCES ON CUSTOMERS' WILLINGNESS ON THIS TECHNOLOGY

Shulan Chen¹, Singha Chaveesuk^{2*}, Wornchanok Chaiyasoonthorn³

¹Ph.D Candidate, KMITL Business School, King Mongkut's Institute of Technology Ladkrabang, Bangkok, 10520. Thailand.

^{2*}Associate Professor, Dr. KMITL Business School, King Mongkut's Institute of Technology Ladkrabang, Bangkok, 10520. Thailand.

³Associate Professor, Dr. KMITL Business School, King Mongkut's Institute of Technology Ladkrabang, Bangkok, 10520. Thailand.

Received: 14 March 2024

Accepted: 18 July 2024

First Online: 30 July 2024

Research Paper

Abstract: This study aims to identify factors influencing individuals' willingness to use mobile payment applications in China. Stimulus–organism–response (SOR) theory served as the foundational framework. Quantitative data were collected from 462 valid questionnaire addressing people's use of mobile payment platforms in various regions of China. Structural Equation Modeling (SEM) results that perceived usefulness and ease of use significantly increase user satisfaction and perceived value. In the same vein, service quality and social influence also positively and significantly influence to satisfaction. In other words, cost has negative and significant impact on perceived value. Perceived value has positive and significant impact on satisfaction. Perceived value and satisfaction have positive and significant impact on willingness to use. The current study with significant findings contributed to fill the gap in the context of China region because only a few studies leveraged the SOR theory to explore mobile payment. The findings also contributed to enrich knowledge of mobile payment applications and provide actionable guidance to help mobile payment operators make strategic decisions. These results could also increase the understanding of mobile payment which paint a more vivid picture of this phenomenon and can enable mobile payment operators to make better strategic choices.

Keywords: Mobile Payment, SOR Theory, Willingness to use, Investigation, China

*Corresponding Author: Singha.ch@kmitl.ac.th, (S. Chaveesuk),
297538746@qq.com, (S. Chen), Wornchanok.ch@kmitl.ac.th, (W. Chaiyasoonthorn)

1. Introduction

Advances in the payment industry continue to affect businesses and consumers with new technologies which are altering people's transaction habits (Qi et al., 2024). Emerging options afford enterprises more chances to engage in electronic commerce (Chaveesuk et al., 2022). China's business digital payment method has developed rapidly with traditional cash payment being partly replaced by non-cash options (Wu et al., 2023). Mobile payment is a digital payment service that uses mobile devices and wireless communication technology to conduct financial transactions (Ye et al., 2023). Mobile payment requires devices supporting mobile payment technology, such as smartphones, smooth and secure networks, etc (Sleiman et al., 2023). Mobile payment is an online digital payment method that allows users to complete transactions more conveniently and quickly without carrying any physical card or cash (Yang et al., 2023). Public health emergencies over the past few years have further inspired people to use this payment mode (Abegao Neto & Figueiredo, 2023; Tounekti et al., 2022). This option makes people's lives more convenient and fosters growth in the commercial economy (Behera et al., 2023; Darko et al., 2023). The status of mobile payment can even reflect a region's degree of economic development (Elsotouhy et al., 2023). This industry's rich business prospects have led many firms to explore potential opportunities, with mobile payment-related companies expected to continue forming (Dang et al., 2023; Mukhopadhyay & Upadhyay, 2022). People's choices are anticipated to expand alongside new mobile payment methods. Industry competition is apt to intensify as well (Chen et al., 2023; Khan et al., 2023).

As mobile banking becomes an integral concern in the current competitive environment. Therefore, different factors which influence to individuals' application choices are of prime interest to mobile payment operators. It is accordingly essential to investigate the aspects that affect customers' willingness to use mobile payment. Author's in the extant literature argued that satisfaction plays a crucial role in increasing willingness to use a product or service by reinforcing positive experiences and meeting expectations effectively (Soliman et al., 2024). When the users of mobile banking find out their needs consistently then they are more likely to choose and continue using that product or service. This cycle of satisfaction increase loyalty and encourages further engagement, ultimately enhancing willingness to use (Soliman et al., 2024). Equally, various stimulus factors namely perceived usefulness, ease of use, and social influence collectively enhance satisfaction by meeting functional needs, minimizing effort, and validating choices through social norms and recommendations (Nuryakin et al., 2023). When users find a product useful, easy to use, and endorsed by others, their satisfaction grows, bolstering their willingness to continue using and advocating for it (Azzahra & Kusumawati, 2023). In seeking significance of previous relationship, study mainly focused on improving willingness to use to increase customer satisfaction. This research intends to bridge this knowledge gap.

Empirically, different studies have been addressed mobile payment and offered insightful gaps. Extant studies have mainly focused of perceived usefulness, ease of use, and social influence on intention to use (Gani et al., 2024; Liesa-Orús et al., 2023; Palamidovska-Sterjadovska et al., 2024; Soliman et al., 2024) while have limited attention on willingness to use. Also previous studies has limited attention on China region which also increase the focus of the study to conduct in Chinese region. In other context, scarce academic work on mobile payment has featured stimulus-organism-

Chinese Mobile Payment Landscape: A Stimulus Organism Response Model Examining Perceived Value, Satisfaction, And Influences On Customers' Willingness On This Technology

response (SOR) theory (Azzahra & Kusumawati, 2023; Nuryakin et al., 2023; Soliman et al., 2024). This theory is useful for uncovering the processes that underlie people's behavior, such as their willingness to use mobile payment (Palamidovska-Sterjadovska et al., 2024). Some scholars have acknowledged SOR theory's applicability to mobile payment and employed it to study people's willingness to use this technology (Lee & Chen, 2022). Therefore, this research constructs a model based on SOR theory to investigate factors affecting Chinese individuals' willingness to use this technology.

The study with this unique model, findings contributed from theoretical and practical perspectives. Theoretically, research implications is to focus on the advancing understanding of mobile payment adoption through the lens of the Stimulus-Organism-Response (SOR) theory, which provides a structured framework to explore how perceived stimuli (usefulness, ease of use, social influence) influence psychological and emotional states (organism), ultimately shaping behavioral responses (willingness to use). Through recognizing the gaps in the extant studies with limited attention on willingness to use mobile payment in China and the underutilization of SOR theory in this context, this study contributes by enhancing theoretical models that explain consumer behavior in technology adoption contexts. In other context, study emphasized the significance of perceived usefulness, ease of use, and social influence in driving willingness to adopt mobile payment technologies among Chinese consumers. Insights derived from the study can inform businesses and policymakers about the factors critical for enhancing user satisfaction and promoting widespread adoption of mobile payment systems. By leveraging SOR theory, which provides a holistic perspective on the factors influencing behavioral intentions, practitioners can develop targeted strategies to improve china mobile payment technologies. The rest of paper divided into further four chapters, literature review where empirical and theoretical studies, research methods where discuss research design, data analysis where discussed the analysis of the study, and discussion part interpreted the results and supported with relevant studies.

2. Review of Literature and Development of Hypothesis

This section provides an overview of relevant literature and proposes 11 hypotheses intended to clarify customers' willingness to use mobile payment options in China.

2.1 Mobile Payment and Willingness to Use This Technology

Mobile payment becomes an important tool to facilitate the people on the national and international level for their easiest payment. It was described by Karnouskos (2004) that mobile payment is worked as a using mobile devices to pay merchants and to provide other data required to complete a transaction. The concept of 'willingness to use' refers to whether consumers wish to purchase or use a product or service. Mobile payment has changed how customers and merchants interact by making transactions simpler and faster (Daragmeh et al., 2021). Scholars have been scrutinizing this payment mode since the early 2000. (Dahlberg et al., 2015) further contended that adapting more theories to mobile payment studies is vital for improving investigations' rigor. Researchers have been applying SOR theory to mobile

payment since 2018, but efforts remain limited as noted earlier. This study therefore builds a model rooted in SOR theory to illuminate the facets influencing Chinese customers' willingness to use mobile payment applications.

2.2 Stimulus–Organism–Response Theory

In brief, SOR theory (Fig1.) asserts that external stimuli elicit psychological reactions and subsequent behavioral responses (e.g., purchase or adoption intentions). A stimulus (“S”) naturally affects a person; external stimulation can arise from objects (e.g., products) or the social environment (e.g., recommendations from friends). The organism (“O”) refers to one’s psychological activities after encountering external stimuli. A response (“R”) is a consequent action (e.g., purchase behavior) following from these psychological outcomes (Chen et al., 2023; Mehrabian, 1974).



Figure 1: SOR Theoretical Model (Mehrabian, 1974)

On the other hand, SOR theory is often used to evaluate consumer behavior, especially intention, and is popular in disciplines such as retailing and tourism. The theory explains how external stimuli, consumer psychology, and behavioral responses mutually operate. Concerning mobile payment, Li (2018) and Jiang (2021) used the framework to discern Chinese individuals' willingness to use this technology. Such willingness appears related to stimuli including product-related factors (e.g., usefulness, ease of use, service quality), the environment, and an organism's psychological reactions. Jiang (2021) took service quality, cost, and social influence as external stimuli; Li (2018) considered usefulness, ease of use, service quality, and social influence. Li (2018) further found that perceived value and satisfaction affect people's willingness to use Chinese mobile payment options. In their case, perceived value and satisfaction constituted the organism, whereas willingness to use represented the response. SOR theory was thus deemed appropriate for the present study.

Usefulness is crucially tied to one's satisfaction with and willingness to use an information system (Bhattacharjee et al., 2008). (Ashraf et al., 2020) pinpointed usefulness as a major predictor of satisfaction and a key element in ones willingness to use a technology. Ferreira et al. (2023) remarked that usefulness is a prerequisite for, and positively related to, satisfaction. Other studies have identified usefulness as integral to satisfaction as well (Shin et al., 2010; Weng et al., 2017). Regarding the digital era, usefulness is a decisive component of satisfaction with respect to the Internet and a mobile technology environment (Wang, 2022). For instance, Yang et al. (2023) ongoing research on massive open online courses indicated that usefulness positively influenced students' satisfaction. Liébana Cabanillas et al. (2020) more generally reported that individuals favor useful technologies. Similarly, Khlaif et al. (2023) reported that people are predisposed to accept a new technology that is useful to them. Other studies have reached the same conclusion (An et al., 2023). Wu (2015)

Chinese Mobile Payment Landscape: A Stimulus Organism Response Model Examining Perceived Value, Satisfaction, And Influences On Customers' Willingness On This Technology

empirically demonstrated that usefulness promotes satisfaction and perceived value. Given these outcomes, the following hypotheses are put forth.

H1: *The usefulness (U) of mobile payment positively affects application users' satisfaction (S).*

H2: *The usefulness (U) of mobile payment positively affects application users' perceived value (PV).*

Ease of use captures one's sense of whether an information system is simple to operate. This notion can shape one's identity and satisfaction with user information systems. Liébana Cabanillas et al. (2020) determined that people prefer easy-to-use technology. Pai et al. (2023), ease of use is a primary factor in mobile payment, such that an application must be simple to use for people to accept it. Flavián et al. (2020) subsequently reaffirmed ease of use as paramount for mobile payment. Whereas complex mobile payment requires deliberate user effort Rahardja et al. (2023), people typically select options that are easy to learn about and deploy (An et al., 2023; Rahardja et al., 2023). Easy-to-operate technology has indeed been found to satisfy customers (Ferreira et al., 2023). On the other hand, further contented that ease of use have positive impact on satisfaction (Hong et al., 2006). Thus, based on previous discussion, hypothesized that,

H3: *The ease of use (EU) of mobile payment positively affects application users' satisfaction (S)*

H4: *The ease of use (EU) of mobile payment positively affects application users' perceived value (PV)*

In this study's context, service quality embodies one's perceived quality of a mobile payment application. Fetra and Pradiani (2023) emphasized the importance of excellent service quality and its role in user satisfaction. High-quality service can evoke strong customer satisfaction (Jiang, 2021). Service quality conveys providers' capabilities such as timeliness, comprehensiveness, and professionalism (Zhou, 2013). Many consumers will be deterred if service providers cannot deliver efficient, thorough, and high-quality service (Fetra & Pradiani, 2023; Zhong & Chen, 2023). Service quality is also essential in mobile payment (Rahardja et al., 2023). For instance, better-quality service in the Internet technology environment can enhance user satisfaction (Ferreira et al., 2023). Stated formally:

H5: *Service quality (SQ) positively affects mobile payment application users' satisfaction (S).*

Social influence can engender personal behavioral changes due to external factors. People occupy social networks, such that others often shape individuals' lifestyles and decisions. Wais and Clemons (2008) stated that social influence encourages satisfaction. Jiang (2021) and Li (2018) both found this influence to promote perceived value. Hameed et al. (2024) specifically mentioned that social influence is critical in mobile payment contexts. Fan et al. (2005) and Mun et al. (2017) noticed that consumers regularly seek input on mobile payment from their relatives, friends, and colleagues. In the same vein, if a person's loved ones heartily recommend using this type of technology, then one's satisfaction with and perceived value of mobile payment should increase (Kurnia & Smith, 2006; Li, 2018) as postulated:

H6: *Social influence (SI) positively affects mobile payment application users' satisfaction (S).*

H7: *Social influence (SI) positively affects mobile payment application users' perceived value (PV).*

Cost is a main consideration when using mobile payment (Yu et al., 2017; Zhong & Chen, 2023), such as to purchase a smartphone. Buyers usually take transaction-related costs into consideration. Payment systems that come with high costs yield lower perceived value for users (Lu et al., 2011; Verkijika & Neneh, 2021). Put simply, costs detract from perceived value (Hsiao, 2011; Jiang, 2021)—including of mobile payment (Lu et al., 2011; Yu et al., 2017). If operators can manage to reduce these costs, then they will likely attract more customers. The following hypothesis is formulated as a result:

H8: *The cost (C) of mobile payment negatively affects application users' perceived value (PV).*

Perceived value involves one's appraisal of a product or service, which in turn affects one's willingness to use it. Value can be determined via transactions or actual use (Figueira et al., 2016). Perceived value is inherently subjective Zeithaml (1988) and has been identified as a determinant of user satisfaction (Cai, 2017; Zhong & Chen, 2023). In addition to satisfaction, it positively influences one's willingness to use an offering (Li, 2018); Roy, 2016). This type of value further functions as a tool with which companies can acquire customers. The following hypotheses are hence developed:

H9: *The perceived value (PV) of mobile payment positively affects application users' satisfaction (S).*

H10: *The perceived value (PV) of mobile payment positively affects application users' willingness to use (WU) this technology.*

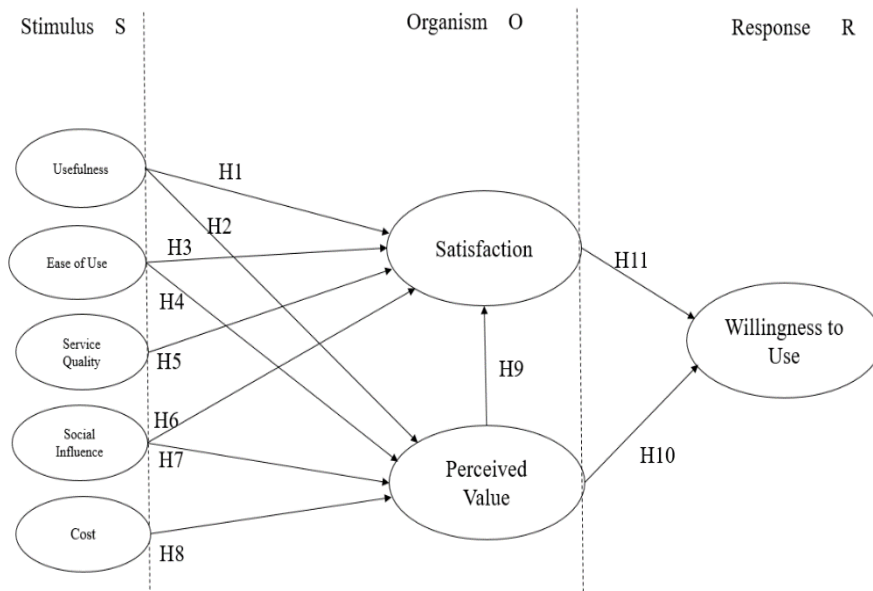

Figure 2: The Conceptual Framework

Chinese Mobile Payment Landscape: A Stimulus Organism Response Model Examining Perceived Value, Satisfaction, And Influences On Customers' Willingness On This Technology

Satisfaction is a feeling of pleasure that manifests from external factors (e.g., when an experience surpasses one's expectations). This element is integral to one's willingness to use a product or service (Ashraf et al., 2020). Ferreira et al. (2023) reported that satisfaction directly affects such willingness, with other scholars (Hong & Slevitch, 2018; Jiang, 2021) finding that satisfaction amplifies willingness to use an item. Zhong and Chen (2023) believed that satisfaction is important in mobile payment; in essence, people should be more inclined to use a mobile payment application if it is satisfying. In terms of the Internet and mobile technology environment, satisfaction molds consumers' willingness to use relevant options. Therefore:

H11: *Satisfaction (S) positively affects mobile payment application users' willingness to use (WU) this technology.*

Based on previous studies' relationship ship, overall, eight latent variables were considered in this study based on the preceding literature review and SOR theory. The following five variables were taken as external stimuli: usefulness, ease of use, service quality, cost, and social influence. The organism comprised satisfaction and perceived value, with willingness to use representing the response. Figure 2 depicts the proposed conceptual framework on people's willingness to use Chinese mobile payment.

3. Method

This study aims to identify factors influencing individuals' willingness to use mobile payment applications in China. To achieve this objective, a quantitative research approach was employed that is considered good when collecting data through survey instruments (Elliott, 2005). On the other hand, the cross-sectional research design was employed where data in the one-time frame. Different authors recommended that it is a more effective design compared to longitudinal when collecting data in one phase or one-time frame (Hassett & Paavilainen-Mäntymäki, 2013). Therefore, the cross-sectional research design was effective for the current study.

3.1 Measures

The hypothesized relationships were tested via a structured questionnaire developed from the literature. The first section solicited respondents' demographic information. The second section addressed eight latent variables. All items about these variables were scored on a 7-point Likert scale (1 = strongly disagree, 7 = strongly agree), consistent with other mobile payment research featuring SOR theory (Kim et al., 2019). Questionnaire data were gathered via random sampling between December 2023 and January 2024; 500 mobile payment users in China were randomly selected. Thirty-eight questionnaires were invalid and excluded from analysis, resulting in a sample of 462 surveys. Respondents hailed from nearly every region of mainland China. SPSS has been deemed suitable for statistical analysis as part of mobile payment research, and AMOS is appropriate for assessing potential relationships between variables using SEM (Chaveesuk et al., 2022; Li, 2018).

3.2 Respondent characteristics

Table 1 presents a profile of the study participants. Less than half of the respondents (39.8%) were women; 60.2% were men. People aged 26–35 (30.5%) constituted the largest proportion of the sample, followed by those aged 36–45 (27.3%), 46–60 (23.8%), 18–25 (14.9%), and above 60 (3.5%). As for occupation, most respondents were in private enterprises (41.1%). Others were either employed by an individual business (18.2%), were students (17.3%), or worked for government agencies/institutions (7.4%) and state-owned enterprises (6.9%); all other occupations constituted 9.1% of the sample. More than one-third of respondents (39.2%) earned 3,000–5,000 yuan per month. About one-quarter (24.0%) earned a monthly income of less 2,000 yuan. Others earned 2,000–3,000 yuan (19.3%), 5,000–8,000 yuan (12.6%), or more than 8,000 yuan (5.0%). The majority of respondents (91.8%) used Alipay, and 90% also used WeChat Pay. Among mobile payment tools, about half of respondents (49.6%) used Alipay, followed by WeChat Pay (45.2%), a digital RMB app (1.9%), Cloud Quick Pass (1.5%), and Yi Pay (0.9%); other apps accounted for 0.9%.

Table 1: Respondent characteristics

Category		Frequency	Percent (%)
Gender	Male	278	60.2
	Female	184	39.8
Age range	18 to 25	69	14.9
	26 to 35	141	30.5
	36 to 45	126	27.3
	46 to 60	110	23.8
	Above 60	16	3.5
Education level	Below High School	75	16.2
	Below Graduation	129	27.9
	Under graduation	187	40.5
	Masters or above	71	15.4
Occupation	Student	80	17.3
	Government agency/institution	34	7.4
	State-owned firm	32	6.9
	Private	190	41.1
	Individual	84	18.2
	Others	42	9.1
Monthly income	Below 2000 CNY	111	24
	2000–3000 CNY	89	19.3
	3000–5000 CNY	181	39.2
	5000–8000 CNY	58	12.6
	8000+ CNY	23	5
Mobile payment application(s) used	Alipay	424	91.80%
	Tenpay (WeChat Pay)	416	90.00%
	Digital RMB app	48	10.40%
	Cloud Quick Pass	174	37.70%
	Yi pay	120	26.00%
	Other	37	8.00%

Chinese Mobile Payment Landscape: A Stimulus Organism Response Model Examining Perceived Value, Satisfaction, And Influences On Customers' Willingness On This Technology

4. Inferential Results

4.1 Reliability and Validity Analyses

Scale reliability was assessed based on two criteria convergent and discriminant validity. The convergent validity was assessed from “alpha, composite reliability (CR), loadings, and average variance extracted (AVE)” which are presented in Table 2. The range of alpha is 0 to 1 (Cronbach, 1951) and is considered acceptable when it is greater than 0.7. The CR value is also acceptable when above 0.7; the AVE is deemed acceptable when over 0.5 (Fornell & Larcker, 1981).

The CR, AVE, and α values were greater than 0.7, 0.5, and 0.7, respectively. The CR and AVE values met (Fornell & Larcker, 1981) recommended thresholds, and α met the threshold suggested by (Cronbach, 1951). The scale constructs' reliability and validity were thus confirmed. Confirmatory factor analysis was next used to evaluate the measurement model. Validity was assessed based on the “comparative fit index (CFI), goodness-of-fit index (GFI), normed fit index (NFI), root mean square error of approximation (RMSEA), and relative Chi-square (χ^2/df)”. Below is Appendix Table 3 shows that each item's factor loading coefficient exceeded 0.5; as such, all items were reasonable. The data fit the model well overall: CFI = 0.977 (≥ 0.9), GFI = 0.902 (≥ 0.9), NFI = 0.923, RMSEA = 0.029 (≤ 0.05), $\chi^2/df = 1.387 (\leq 2)$ (Bentler & Bonnet, 1980).

4.2 Hypothesis Testing

Scholars have recognized that Structural Equation Modeling (SEM) is widely used in the fields of economy, finance, consumer behavior, business management, etc. The advantage of SEM is that it can be used to verify the relationship between variables when conducting empirical research (Jiang, 2021). The structural model results shown that usefulness positively influenced respondents' satisfaction with the mobile payment application (estimate = 0.238, $p < 0.001$), causing H1 to be supported. Usefulness also had a positive impact on respondents' perceived value of the app (estimate = 0.285, $p < 0.001$). H2 was hence supported. Ease of use promoted users' satisfaction with the app (estimate = 0.25, $p < 0.001$) as well as the app's perceived value (estimate = 0.274, $p < 0.001$), lending support to H3 and H4. Service quality (SQ) positively affected users' satisfaction with the mobile payment app (estimate = 0.295, $p < 0.001$), as did social influence (estimate = 0.26, $p < 0.001$). H5 and H6 were therefore accepted. Social influence also promoted users' perceived value of the app (estimate = 0.29, $p < 0.001$), whereas cost (C) negatively affected this aspect (estimate = -0.339, $p < 0.001$). Thus, H7 and H8 were accepted. Perceived value had a positive effect on users' satisfaction with the mobile payment app (estimate = 0.136, $p < 0.05$) and on their willingness to use the app (estimate = 0.418, $p < 0.001$). H9 and H10 were hence supported. Satisfaction also positively influenced respondents' willingness to use the app (estimate = 0.243, $p < 0.001$). H11 was accordingly supported. The data fit the model well overall: CFI = 0.972 (≥ 0.9), GFI = 0.896 (≥ 0.9), NFI = 0.918, RMSEA = 0.032 (≤ 0.05), $\chi^2/df = 1.466 (\leq 2)$; (Bentler & Bonett, 1980).

Table 2: Convergent reliability (CR) and average variance extracted (AVE)

	U	EU	SQ	SI	C	S	PV	WU	AVE	CR	A
U	0.806								0.651	0.881	0.881
EU	0.286	0.782							0.611	0.824	0.816
SQ	0.21	0.161	0.811						0.657	0.852	0.851
SI	0.229	0.103	0.201	0.817					0.668	0.934	0.934
C	-0.231	-0.171	-0.096	-0.132	0.805				0.648	0.902	0.901
S	0.505	0.455	0.464	0.461	-0.124	0.812			0.661	0.921	0.922
PV	0.512	0.445	0.184	0.433	-0.489	0.537	0.814		0.675	0.936	0.935
WU	0.182	0.204	0.181	0.137	-0.182	0.482	0.564	0.822	0.663	0.932	0.932

Note. U = usefulness; EU = ease of use; SQ = service quality; SI = social influence; C = cost; S = satisfaction; PV = perceived value; WU = willingness to use.

Chinese Mobile Payment Landscape: A Stimulus Organism Response Model Examining Perceived Value, Satisfaction, And Influences On Customer's Willingness On This Technology

The research hypotheses were tested via SEM. The outcomes are illustrated in Figure 3 and summarized in Table 3.

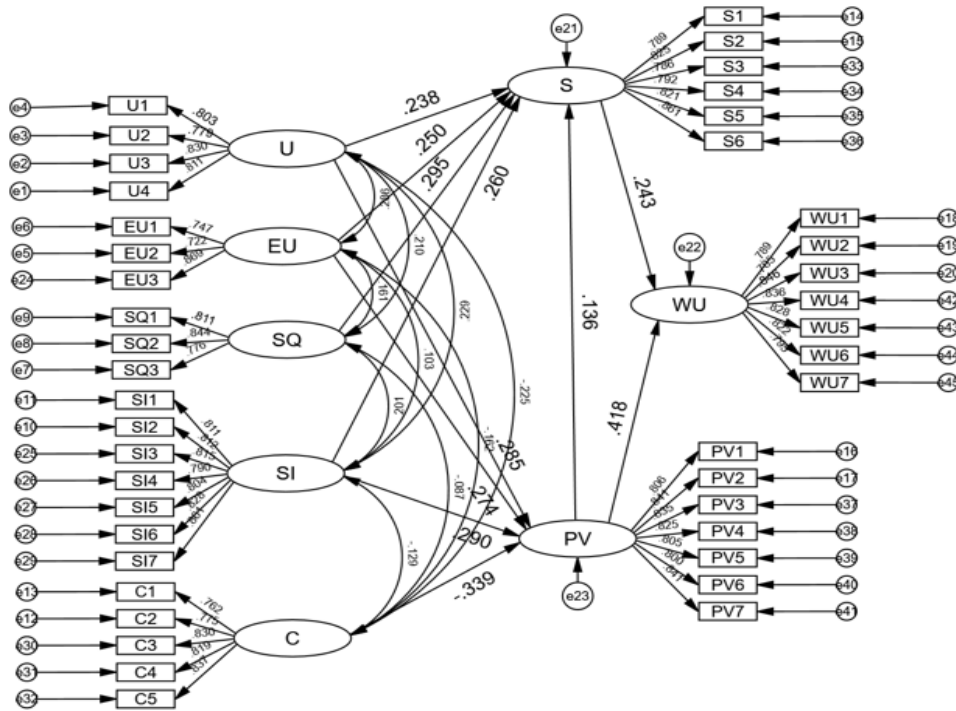

Figure 3: Results of SEM analysis

Table 3: Hypothesis testing results

Hypothesis	Estimate	S.E.	C.R. (t value)	p value	Result
H1: U→S	0.238	0.045	5.136	***	Supported
H2: U→PV	0.285	0.043	6.639	***	Supported
H3: EU→S	0.25	0.051	5.384	***	Supported
H4: EU→PV	0.274	0.049	6.357	***	Supported
H5: SQ→S	0.295	0.043	6.932	***	Supported
H6: SI→S	0.26	0.041	6.009	***	Supported
H7: SI→PV	0.29	0.038	7.32	***	Supported
H8: C→PV	-0.339	0.044	-8.128	***	Supported
H9: PV→S	0.136	0.05	2.638	0.008	Supported
H10: PV→WU	0.418	0.054	7.687	***	Supported
H11: S→WU	0.243	0.053	4.659	***	Supported

Note. U = usefulness; EU = ease of use; SQ = service quality; SI = social influence; C = cost; S = satisfaction; PV = perceived value; WU = willingness to use; ***p < 0.001.

5. Discussion

This study aimed to identify factors influencing individuals' willingness to use mobile payment applications in China. To achieve this objective, a quantitative

research approach and cross sectional research design were employed. The structural Equation Modeling (SEM) results shown that usefulness has positively and significantly influence to satisfaction. This finding emphasized the critical role of perceived usefulness which is significantly increasing the user's satisfaction of mobile banking services in China region. This finding is consistent with SAR, which posits that perceived usefulness is a primary determinant of user satisfaction (Shah et al., 2022; Waheed & Jam, 2010). Users who find mobile banking features beneficial and relevant are more likely to report higher levels of satisfaction. The results is also consistent with the empirical study (Jiang, 2021; Khalil et al., 2023; Li, 2018) which is also shown that perceived usefulness significantly enhances user satisfaction in various technological contexts. These finding shown that mobile banking providers in China are prioritizing on the development of features that address users' practical needs and enhance functionality could lead to improved satisfaction outcomes. In other words, perceived usefulness also positively and significantly influence to the perceived value. The results supported that when perceived usefulness increased then users perceived value also increased which supported with the SAR (Davis et al., 1989). The results is further aligned with different empirical findings (Faqih, 2016; Seligman, 2001; Wang & Sahid, 2024), where they also found that perception of value is often influenced by the extent to which a service meets users' needs and enhances their experience. Therefore, these finding in the context of China internet banking users emphasizing the practical benefits and advantages of their services can enhance users' perceived value that could lead to banking sector sustainability.

The further results shown that ease of use also significantly influence to the satisfaction of any individual for using mobile banking in China. This results highlighted the highlighted the significant of user-friendly interfaces in mobile banking. This finding in consistent with the following studies which suggested that ease of use is a critical factor influencing user satisfaction with technology (Azzahra & Kusumawati, 2023; Wilson et al., 2021). Users who find mobile banking applications easy to navigate are more likely to experience higher satisfaction levels. In other words, complex mobile payment can call for intentional effort. Ease of use is thus salient for mobile payment (Liébana Cabanillas et al., 2020; Mun et al., 2017). Consumers often highly value usefulness and ease of use when assessing product performance (Arham et al., 2022; Hong & Slevitch, 2018; Wiese & Humbani, 2020). Therefore, these findings shown that internet banking users in China should design intuitive and accessible interfaces which is crucial for enhancing user satisfaction which can increase the sustainability of china banking sectors.

In addition, perceived ease of use also positively and significantly influence to perceived value which indicated that that users who find mobile banking services easy to use also perceive them as more valuable. The results supported the notion with following studies (Luo et al., 2024; Sudaryanto et al., 2023) where they also found the user-friendly design which can enhance users' perceptions of value because when users can easily interact with mobile banking services, they are more likely to perceive these services as offering greater value. These findings enforced that mobile banking providers in China should focus on simplifying the user experience to improve users' perceived value and satisfaction. Service quality and satisfaction result also positively and significantly affected on mobile banking users of china. This result indicated the significance of high service quality in mobile banking. The research results are supported with following studies (Rashid & Rasheed, 2024; Venkatakrishnan et al.,

Chinese Mobile Payment Landscape: A Stimulus Organism Response Model Examining Perceived Value, Satisfaction, And Influences On Customer's Willingness On This Technology

2023), where they also found that service quality is a key determinant of customer satisfaction. This users perceptions findings shown that mobile banking, factors such as reliability, responsiveness, and assurance are crucial for ensuring user satisfaction. This results suggested that mobile banking's providers in china should prioritized on maintaining high service standard to increase user satisfaction and build long-term customer relationships with their customers.

On the other hand, social influence also positively and significantly influence to the satisfaction which highlighted the role of peer opinions and social factors in shaping user satisfaction. The results supported with relevant studies (Bhukya & Paul, 2023; Pai et al., 2023) which also suggested that user perceptions and behaviors are often shaped by social interactions and recommendations. They also further concluded that users who receive positive feedback and endorsements from their social networks are more likely to be satisfied with mobile banking services. These empirical findings indorsed that in China leveraging social influence through positive user testimonials and recommendations could be an effective strategy to enhance user satisfaction that could increase banks sustainability. Social influence also positively and significantly influence to the perceived values which indicated that users who are influenced by their social networks perceive mobile banking services as more valuable. This results is further supported with following studies (Rasoolimanesh et al., 2023; Shah & Asghar, 2023) where they also enforced that social factors are playing a significant role in shaping users' perceptions of value. Social proof and community endorsements could increase the perceived value of mobile banking services. Therefore, mobile banking providers in China should consider incorporating social influence elements into their marketing strategies to increase perceived value which could increase the customer attraction in banking sector.

In other sense, cost and perceived values relationship positively and significantly affect which advocated that higher costs reduce users' perceptions of value. The results is consistent with following studies (Ruelas, 2022; Tannady & Dewi, 2024; Zhong & Chen, 2023), where they also conducted research on price sensitivity and perceived value, which indicates that users are less likely to perceive high-cost services as valuable (Wang, 2022; Zeithaml, 1988). This results enforced that mobile banking providers in China which is offering cost-effective solutions and transparent pricing that could improve users' perceptions of value and enhance their competitive advantage in market. The perceived values also significantly influence to satisfaction of China internet banking users. These findings shown that in China higher perceived value contributes to greater user satisfaction. These findings shown that when users believe that they are receiving good value from mobile banking services, their satisfaction levels tend to increase. The result is supported the notion with following studies (Cankül et al., 2024; Chang et al., 2024) where they also found that perceived value is a key driver of satisfaction in various service contexts. These findings shown that mobile banking providers in China should focus on enhancing the perceived value of their services to improve overall user satisfaction.

Perceived values and willingness relationship positively and significantly influenced ant this relationship underlined that users who perceive higher value in mobile banking services are more willing to continue using them. This result supported with following empirical studies (Baidoun & Salem, 2024; Alemany et al., 2023; Ciu & Wijayanti, 2024). These studies enforced that perceived value is a strong

predictor of user engagement and continued usage. Therefore, China banking sector should prioritize on the enhancement of perceived value which is crucial for increasing users' willingness to use and ensuring long-term engagement with their services. Satisfaction also has positive and significant influence on willingness to use which is emphasizing the importance of user satisfaction in driving continued use of mobile banking services. The result is consistent with following studies (Adu-Gyamfi et al., 2024; Amfo et al., 2024) which shown that satisfied users are more likely to remain loyal and continue using a service (Oliver, 1980). This results shown that mobile banking users in china should prioritize on user satisfaction which is essential for increasing ongoing user engagement and maintaining a competitive position in the market. The above findings shown that all indicators are important to increase the willingness to use.

6. Implications

The study with significant findings holds theoretical and practical implications. Theoretically, study have several implications. At first, study on mobile payment conceptual framework proposed on SOSR model theory. Various external stimulus (i.e., usefulness, ease of use, service quality, cost, social influence) were treated as antecedents of the organism's psychological reactions (i.e., perceived value, satisfaction), which mediated responses (i.e., willingness to use). The findings contributed that mobile payment literature by introducing SOR theory to this domain is a popular payment method in China and is important on a global scale. At second, positive ease of use impact on both of satisfaction and further validated that user-friendly design not only improves satisfaction but also elevates perceived value, thus broadening the model's application. At third, study with significant impact of service quality also contributed that the service quality model high service quality is essential for achieving user satisfaction. At forth, cost-benefit negative impact contributed to the literature in the context of price sensitivity and value perception which is showing that higher costs diminish the perceived value of mobile banking services. This finding aligns with value-based pricing theories and highlights the importance of cost management in enhancing perceived value. Lastly, study findings could also be a reference for scholars aiming to investigate mobile payment in greater depth in other countries.

With theoretical implications, the study also has some practical implications. Firstly, study findings could help to policymaker in establishing a standards for user-friendly interfaces and effective functionalities to ensure that mobile banking services should meet users' needs and improve overall satisfaction. At second, study also contributed in providing guidelines to investors in prioritize their funding opportunities that support the development of high-quality mobile banking services. Investing in companies that demonstrate a commitment to improving service quality and enhancing perceived value can yield positive returns, as these factors are crucial for attracting and retaining users. At third, study also enforced that regulators should address the impact of cost on perceived value by implementing pricing transparency and fair competition policies. Ensuring that mobile banking services are competitively priced and transparent in their fee structures can enhance users' perceived value and prevent market distortions. The study findings could also benefit to other researchers

Chinese Mobile Payment Landscape: A Stimulus Organism Response Model Examining Perceived Value, Satisfaction, And Influences On Customer's Willingness On This Technology

in conducting their in the banking sectors that could increase banking sector competitive advantage.

7. Conclusion

Taking SOR theory as its foundation, this study examined individuals' willingness to adopt mobile payment by identifying pertinent influencing factors. Data were collected from the mobile banking users employing quantitative research approach. The results findings shown that perceived usefulness and ease of use significantly increase user satisfaction and perceived value. In the same vein, service quality also positively and significantly influence to satisfaction. Also, perceived value positively and significantly impacts willingness to use, and social influence also positively and significantly affects both perceived value and satisfaction. Theoretically, study findings highlighted the importance of perceived usefulness and ease of use in shaping user experiences. The study findings also increase the new area of research for other researchers to conduct their research that could increase strength of current research extended model. Practically, study findings also suggested that policymakers should focus on user-friendly design and service quality, investors should support innovative and high-quality services, and regulators should ensure fair pricing and transparency

8. Limitations and future research

Certain limitations of this study leave room for future work. First, the sample consisted solely of mobile payment users in China. Economic globalization has ignited concerns about transactions among different countries. Additional research is needed to verify whether the conceptual framework proposed here applies to other locations. Subsequent efforts could address national conditions (e.g., regional, political, economic, and cultural attributes) in hopes of enhancing the model's applicability. Second, eight latent variables were tested in this case. Follow-up analysis can consider other potentially relevant factors. In addition, the study does not use moderating variables, future studies could use moderating variables to increase the predictive relevance of the study. Finally, given this study's use of SEM, other approaches can be employed in the future to further validate the findings.

Author Contributions:

Conceptualization: C.S, C.S and C.W.

Data curation: C.S.

Formal analysis: C.S and C.S.

Funding acquisition: C.S.

Investigation: C.S.

Methodology: C.S and C.S.

Resources: C.S, C.S and C.W.

Software: C.S.

Supervision: C.S and C.W.

Visualization: C.S.

Writing – original draft: C.S.

Writing – review & editing: C.S and C.W.

Competing Interests

The authors declare no competing interests.

Informed Consent

All respondents took part voluntarily, provided informed consent, and could leave or stop the survey at any time without penalty. All respondents remained anonymous.

References

- Abegao Neto, F. L., & Figueiredo, J. C. B. d. (2023). Effects of age and income moderation on adoption of mobile payments in Brazil. *Innovation & Management Review*, 20(4), 353-364. <https://doi.org/10.1108/INMR-06-2021-0109>
- Adu-Gyamfi, G., Song, H., Nketiah, E., Obuobi, B., Wu, Q., & Cudjoe, D. (2024). Refueling convenience and range satisfaction in electric mobility: Investigating consumer willingness to use battery swap services for electric vehicles. *Journal of Retailing and Consumer Services*, 79, 103800. <https://doi.org/10.1016/j.jretconser.2024.103800>
- Aleman, E. G., Fernández, E. N., & Ramos, M. F. (2023). Towards an architecture in-gens: Learning, 'Tejiendo la Calle', new tools for participation in architectural projects. *Rita Revista Indexada de Textos Academicos*, (19), 76-95. <https://redfundamentos.com/menu-script/index.php/rita/article/view/12/13>
- Amfo, B., Abankwah, V., & Tanko, M. (2024). Consumer satisfaction with local rice attributes and willingness to pay for improvement by internal migrants and natives in urban Ghana. *Journal of Agribusiness in Developing and Emerging Economies*, 14(3), 587-606. <https://doi.org/10.1108/JADEE-07-2022-0160>
- An, S., Eck, T., & Yim, H. (2023). Understanding consumers' acceptance intention to use mobile food delivery applications through an extended technology acceptance model. *Sustainability*, 15(1), 832. <https://doi.org/10.3390/su15010832>
- Arham, M. A., Akib, F. H. Y., & Anam, H. (2022). Does The Education Sector Contribute to Overcoming Poverty in The Tomini Bay Area of Indonesia? Method of Moments Quantile Approach. *International Journal of Economics and Finance Studies*, 14(4), 114-134. <https://agbioforum.org/sobiad.org/menuscript/index.php/ijefs/article/view/1306>
- Ashraf, M. A., Keshavarz, P., Hosseinpour, P., Erfani, A., Roshanshad, A., Pourdast, A., Nowrouzi-Sohrabi, P., Chaichian, S., & Poordast, T. (2020). Coronavirus disease 2019 (COVID-19): a systematic review of pregnancy and the possibility of vertical transmission. *Journal of reproduction & infertility*, 21(3), 157. <https://www.ncbi.nlm.nih.gov/pmc/articles/PMC7362089/>

Chinese Mobile Payment Landscape: A Stimulus Organism Response Model Examining Perceived Value, Satisfaction, And Influences On Customer's Willingness On This Technology

- Azzahra, T. R., & Kusumawati, N. (2023). The Impact of Mobile Service Quality, Perceived Value, Perceived Usefulness, Perceived Ease of Use, Customer Satisfaction Towards Continuance Intention to Use MyTelkomsel App. *Journal of Consumer Studies and Applied Marketing*, 1(1), 46-60. <https://www.researchgate.net/profile/Nurrani-Kusumawati-2/publication/372379019>
- Baidoun, S. D., & Salem, M. Z. (2024). The moderating role of perceived trust and perceived value on online shopping behavioral intention of Palestinian millennials during COVID-19. *Competitiveness Review: An International Business Journal*, 34(1), 125-143. <https://doi.org/10.1108/CR-10-2022-0161>
- Behera, R. K., Bala, P. K., & Rana, N. P. (2023). Assessing factors influencing consumers' non-adoption intention: exploring the dark sides of mobile payment. *Information Technology & People*, 36(7), 2941-2976. <https://doi.org/10.1108/ITP-03-2022-0223>
- Bentler, P. M., & Bonett, D. G. (1980). Significance tests and goodness of fit in the analysis of covariance structures. *Psychological bulletin*, 88(3), 588. <https://psycnet.apa.org/doi/10.1037/0033-2909.88.3.588>
- Bhattacharjee, A., Perols, J., & Sanford, C. (2008). Information technology continuance: A theoretic extension and empirical test. *Journal of Computer Information Systems*, 49(1), 17-26. <https://doi.org/10.1080/08874417.2008.11645302>
- Bhukya, R., & Paul, J. (2023). Social influence research in consumer behavior: What we learned and what we need to learn?—A hybrid systematic literature review. *Journal of Business Research*, 162, 113870. <https://doi.org/10.1016/j.jbusres.2023.113870>
- Cai, Q. (2017). Research on the Influencing Factors of User Satisfaction with the Third Party Mobile Payment——The Case of Alipay. *Dissertation, Wuhan University of Technology*. <https://www.cnki.net/kns/defaultresult/index>
- Cankül, D., Kaya, S., & Kızıltaş, M. Ç. (2024). The effect of gastronomic experience on restaurant image, customer perceived value, customer satisfaction and customer loyalty. *International Journal of Gastronomy and Food Science*, 36, 100908. <https://doi.org/10.1016/j.ijgfs.2024.100908>
- Chang, I.-H., Hsu, P.-C., & Chen, R.-S. (2024). The effects of trust on user satisfaction with parenting apps for Taiwanese parents: The mediating roles of social ties and perceived value. *Education and Information Technologies*, 1-19. <https://doi.org/10.1007/s10639-024-12471-y>
- Chaveesuk, S., Khalid, B., & Chaiyasoonthorn, W. (2022). Continuance intention to use digital payments in mitigating the spread of COVID-19 virus. *International Journal of Data and Network Science*, 6(2), 527-536. <http://dx.doi.org/10.5267/j.ijdns.2021.12.001>
- Chen, F., Jiang, G., & Xiao, J. J. (2023). Mobile payment use and payment satisfaction: mediation and moderation analyses. *International Journal of Bank Marketing*, 41(4), 727-748. <https://doi.org/10.1108/IJBM-09-2022-0406>
- Ciu, E., & Wijayanti, C. A. (2024). The Role of Consumer Ethnocentrism, Perceived Quality, Perceived Price, and Perceived Brand Image on Willingness to Buy Erigo Clothing. *Klabat Journal of Management*, 5(1), 49-71. <https://doi.org/10.60090/kjm.v5i1.1056.49-71>
- Cronbach, L. J. (1951). Coefficient alpha and the internal structure of tests. *psychometrika*, 16(3), 297-334. <https://doi.org/10.1007/BF02310555>

Shulan Chen, Singha Chaveesuk, Wornchanok Chaiyasoonthorn/ Oper. Res. Eng. Sci. Theor. Appl. 7(2)2024 59-84

- Dahlberg, T., Guo, J., & Ondrus, J. (2015). A critical review of mobile payment research. *Electronic commerce research and applications*, 14(5), 265-284. <https://doi.org/10.1016/j.elerap.2015.07.006>
- Dang, T.-Q., Tan, G. W.-H., Aw, E. C.-X., Ooi, K.-B., Metri, B., & Dwivedi, Y. K. (2023). How to generate loyalty in mobile payment services? An integrative dual SEM-ANN analysis. *International Journal of Bank Marketing*, 41(6), 1177-1206. <https://doi.org/10.1108/IJBM-05-2022-0202>
- Daragmeh, A., Lentner, C., & Sági, J. (2021). FinTech payments in the era of COVID-19: Factors influencing behavioral intentions of "Generation X" in Hungary to use mobile payment. *Journal of Behavioral and Experimental Finance*, 32, 100574. <https://doi.org/10.1016/j.jbef.2021.100574>
- Darko, A. P., Liang, D., Xu, Z., Agbodah, K., & Obiora, S. (2023). A novel multi-attribute decision-making for ranking mobile payment services using online consumer reviews. *Expert Systems with Applications*, 213, 119262. <https://doi.org/10.1016/j.eswa.2022.119262>
- Davis, F. D. (1989). Perceived usefulness, perceived ease of use, and user acceptance of information technology. *MIS Quarterly*, 13(3), 319-340. <https://doi.org/10.2307/249008>
- Elliott, J. (2005). Using narrative in social research: Qualitative and quantitative approaches. *Sage Publications*, 232 <https://www.torrossa.com/en/resources/an/4913882>
- Elsotouhy, M. M., Mobarak, A. M., Dakrory, M. I., Ghonim, M. A., & Khashan, M. A. (2023). An integrated model predicting the drivers of mobile payment outcomes: evidence from emerging markets. *EuroMed Journal of Business*. <https://doi.org/10.1108/EMJB-02-2023-0046>
- Fan, J., McCandliss, B. D., Fossella, J., Flombaum, J. I., & Posner, M. I. (2005). The activation of attentional networks. *Neuroimage*, 26(2), 471-479. <https://doi.org/10.1016/j.neuroimage.2005.02.004>
- Faqih, K. (2016). Which is more important in e-learning adoption, perceived value or perceived usefulness? Examining the moderating influence of perceived compatibility. *E-Journal of Education*, 37-67. <https://www.researchgate.net/profile/Khaled-Al-Fagih/publication/295909368>
- Ferreira, A., Silva, G. M., & Dias, Á. L. (2023). Determinants of continuance intention to use mobile self-scanning applications in retail. *International Journal of Quality & Reliability Management*, 40(2), 455-477. <https://doi.org/10.1108/IJQRM-02-2021-0032>
- Fetra, R., & Pradiani, T. (2023). The influence of price, facilities, and service quality on re-staying interest. *ADI Journal on Recent Innovation*, 4(2), 184-193. <https://doi.org/10.34306/ajri.v4i2.867>
- Figueira, J. R., Mousseau, V., & Roy, B. (2016). ELECTRE methods. *Multiple criteria decision analysis: State of the art surveys*, 155-185. https://doi.org/10.1007/978-1-4939-3094-4_5
- Flavián, C., Guinaliu, M., & Lu, Y. (2020). Mobile payments adoption-introducing mindfulness to better understand consumer behavior. *International Journal of Bank Marketing*, 38(7), 1575-1599. <https://doi.org/10.1108/IJBM-01-2020-0039>

Chinese Mobile Payment Landscape: A Stimulus Organism Response Model Examining Perceived Value, Satisfaction, And Influences On Customer's Willingness On This Technology

- Fornell, C., & Larcker, D. F. (1981). Evaluating structural equation models with unobservable variables and measurement error. *Journal of marketing research*, 18(1), 39-50. <https://doi.org/10.1177/002224378101800104>
- Gani, M. O., Rahman, M. S., Bag, S., & Mia, M. P. (2024). Examining behavioural intention of using smart health care technology among females: dynamics of social influence and perceived usefulness. *Benchmarking: An International Journal*, 31(2), 330-352. <https://doi.org/10.1108/BIJ-09-2022-0585>
- Hameed, I., Akram, U., Khan, Y., Khan, N. R., & Hameed, I. (2024). Exploring consumer mobile payment innovations: An investigation into the relationship between coping theory factors, individual motivations, social influence and word of mouth. *Journal of Retailing and Consumer Services*, 77, 103687. <https://doi.org/10.1016/j.jretconser.2023.103687>
- Hassett, M. E., & Paavilainen-Mäntymäki, E. (2013). Longitudinal research in organizations: an introduction. In *Handbook of longitudinal research methods in organisation and business studies* (pp. 1-22). Edward Elgar Publishing. <https://www.elgaronline.com/downloadpdf/edcoll/9780857936783/9780857936783.00008.pdf>
- Hong, C., & Slevitch, L. (2018). Determinants of customer satisfaction and willingness to use self-service kiosks in the hotel industry. *Journal of Tourism & Hospitality*, 7(5), 1-7. <https://www.researchgate.net/profile/Lisa-Slevitch-2/publication/330197092>
- Hong, S., Thong, J. Y., & Tam, K. Y. (2006). Understanding continued information technology usage behavior: A comparison of three models in the context of mobile internet. *Decision support systems*, 42(3), 1819-1834. <https://doi.org/10.1016/j.dss.2006.03.009>
- Hsiao, K. L. (2011). Why internet users are willing to pay for social networking services. *Online Information Review*, 35(5), 770-788. <https://doi.org/10.1108/14684521111176499>
- Jiang, S. (2021). Research on the Influencing Factors of Third-party Mobile Payment APP Users' Use Intention. *Dissertation, Guilin University of Technology*.1-63 <https://www.cnki.net/kns/defaultresult/index>
- Karnouskos, S. (2004). Mobile payment: a journey through existing procedures and standardization initiatives. *IEEE Communications Surveys & Tutorials*, 6(4), 44-66. <https://doi.org/10.1109/COMST.2004.5342298>
- Khalil, M. I., Haque, R., Senathirajah, A. R. B. S., Al-Ainati, S., Alkhatib, H., Ahmed, S., & Chowdhury, B. (2023). An Analysis of Structural Path Modelling of CSR Dimensions with the Mediation Effect of Customer Demand and Satisfaction on Revisit Intention. *International Journal of Operations and Quantitative Management*, 29(2). <https://submissions.ijocm.org/index.php/ijocm/article/view/247>
- Khan, S., Khan, S. U., Khan, I. U., Khan, S. Z., & Khan, R. U. (2023). Understanding consumer adoption of mobile payment in Pakistan. *Journal of Science and Technology Policy Management*(ahead-of-print). <https://doi.org/10.1108/JSTPM-07-2021-0110>
- Khlaif, Z. N., Sanmugam, M., & Ayyoub, A. (2023). Impact of technostress on continuance intentions to use mobile technology. *The Asia-Pacific Education Researcher*, 32(2), 151-162. <https://doi.org/10.1007/s40299-021-00638-x>

Shulan Chen, Singha Chaveesuk, Wornchanok Chaiyasoonthorn/ Oper. Res. Eng. Sci. Theor. Appl. 7(2)2024 59-84

- Kim, H., Park, J., Bennis, M., & Kim, S.-L. (2019). Blockchain on-device federated learning. *IEEE Communications Letters*, 24(6), 1279-1283. <https://doi.org/10.1109/LCOMM.2019.2921755>
- Kurnia, S., & Smith, S. (2006). Consumers Perception of Mobile Internet in Australia. *인터넷비즈니스 연구*, 7(2), 41-61. <https://kiss.kstudy.com/Detail/Ar?key=2708364>
- Lee, J.-C., & Chen, X. (2022). Exploring users' adoption intentions in the evolution of artificial intelligence mobile banking applications: the intelligent and anthropomorphic perspectives. *International Journal of Bank Marketing*, 40(4), 631-658. <https://doi.org/10.1108/IJBM-08-2021-0394>
- Li, W., Hu, B., Ji, D. . (2018). Understanding the Behavioral Incentive of Using E-book Reader Apps—An Investigation from UTAUT and VAM Perspectives. *Library Tribune*. <https://www.cnki.net/kns/defaultresult/index>
- Liébana Cabanillas, F. J., García Maroto, I., Muñoz Leiva, F., & Ramos de Luna, I. (2020). Mobile Payment Adoption in the Age of Digital Transformation: The Case of Apple Pay. <http://dx.doi.org/10.3390/su12135443>
- Liesa-Orús, M., Latorre-Cosculluela, C., Sierra-Sánchez, V., & Vázquez-Toledo, S. (2023). Links between ease of use, perceived usefulness and attitudes towards technology in older people in university: A structural equation modelling approach. *Education and Information Technologies*, 28(3), 2419-2436. <https://doi.org/10.1007/s10639-022-11292-1>
- Lu, Y., Yang, S., Chau, P. Y., & Cao, Y. (2011). Dynamics between the trust transfer process and intention to use mobile payment services: A cross-environment perspective. *Information & management*, 48(8), 393-403. <https://doi.org/10.1016/j.im.2011.09.006>
- Luo, J., Ahmad, S. F., Alyaemni, A., Ou, Y., Irshad, M., Alyafi-Alzahri, R., Alsanie, G., & Unnisa, S. T. (2024). Role of perceived ease of use, usefulness, and financial strength on the adoption of health information systems: the moderating role of hospital size. *Humanities and Social Sciences Communications*, 11(1), 1-12. <https://doi.org/10.1057/s41599-024-02976-9>
- Mehrabian, A. (1974). An approach to environmental psychology. *Massachusetts Institute of Technology*. 266. <https://psycnet.apa.org/record/1974-22049-000?ref=nepopularna.org>
- Mukhopadhyay, S., & Upadhyay, P. (2022). Institutional intervention in technology innovation: the struggle to increase mobile payment adoption. *Digital Policy, Regulation and Governance*, 24(1), 74-92. <https://doi.org/10.1108/DPRG-01-2021-0002>
- Mun, Y. P., Khalid, H., & Nadarajah, D. (2017). Millennials' perception on mobile payment services in Malaysia. *Procedia Computer Science*, 124, 397-404. <https://doi.org/10.1016/j.procs.2017.12.170>
- Nuryakin, N., Rakotoarizaka, N. L. P., & Musa, H. G. (2023). The effect of perceived usefulness and perceived easy to use on student satisfaction the mediating role of attitude to use online learning. *APMBA (Asia Pacific Management and Business Application)*, 11(3), 323-336. <https://doi.org/10.21776/ub.apmba.2023.011.03.5>
- Oliver, R. L. (1980). A cognitive model of the antecedents and consequences of satisfaction decisions. *Journal of marketing research*, 17(4), 460-469. <https://doi.org/10.1177/002224378001700405>

Chinese Mobile Payment Landscape: A Stimulus Organism Response Model Examining Perceived Value, Satisfaction, And Influences On Customer's Willingness On This Technology

- Pai, C. K., Chen, H., Lee, T. J., Hyun, S. S., Liu, Y., & Zheng, Y. (2023). The impacts of under-tourism and place attachment on residents' life satisfaction. *Journal of Vacation Marketing*, 13567667231164807. <https://doi.org/10.1177/13567667231164807>
- Palamidovska-Sterjadovska, N., Prodanova, J., & Ciunova-Shuleska, A. (2024). Why do customers value m-banking apps? A stimulus-organism-response perspective. *Spanish Journal of Marketing-ESIC*. <https://doi.org/10.1108/SJME-01-2023-0024>
- Qi, Y., Sajadi, S. M., Baghaei, S., Rezaei, R., & Li, W. (2024). Digital technologies in sports: Opportunities, challenges, and strategies for safeguarding athlete wellbeing and competitive integrity in the digital era. *Technology in Society*, 102496. <https://doi.org/10.1016/j.techsoc.2024.102496>
- Rahardja, U., Sigalingging, C. T., Putra, P. O. H., Nizar Hidayanto, A., & Phusavat, K. (2023). The impact of mobile payment application design and performance attributes on consumer emotions and continuance intention. *Sage Open*, 13(1), 21582440231151919. <https://doi.org/10.1177/21582440231151919>
- Rashid, D. A., & Rasheed, D. R. (2024). Logistics service quality and product satisfaction in e-commerce. *Sage Open*, 14(1), 21582440231224250. <https://doi.org/10.1177/21582440231224250>
- Rasoolimanesh, S. M., Iranmanesh, M., Seyfi, S., Ari Ragavan, N., & Jaafar, M. (2023). Effects of perceived value on satisfaction and revisit intention: Domestic vs. international tourists. *Journal of Vacation Marketing*, 29(2), 222-241. <https://doi.org/10.1177/13567667221086326>
- Ruelas, J. D. (2022). Public sphere between online and offline space. *Rita Revista Indexada de Textos Academicos*, (17), 100-105. <https://redfundamentos.com/menu-script/index.php/rita/article/view/40/40>
- Seligman, L. S. (2001). *Perceived value impact as an antecedent of perceived usefulness, perceived ease of use, and attitude: A perspective on the influence of values on technology acceptance*. The University of Texas at Austin. <https://www.proquest.com/openview/07620866d9de7830e1810589fecdb491/1?pq-origsite=gscholar&cbl=18750&diss=y>
- Shah, N. H., Rabari, K., & Patel, E. (2022). A deteriorating inventory model under overtime production and credit policy for stock-and price sensitive demand function. *Operational Research in Engineering Sciences: Theory and Applications*, 5(2), 85-98. <https://doi.org/10.31181/oresta210322106s>
- Shah, S. S., & Asghar, Z. (2023). Dynamics of social influence on consumption choices: A social network representation. *Heliyon*, 9(6). <https://doi.org/10.1016/j.heliyon.2023.e17146>
- Shin, Y. M., Lee, S. C., Shin, B., & Lee, H. G. (2010). Examining influencing factors of post-adoption usage of mobile internet: Focus on the user perception of supplier-side attributes. *Information Systems Frontiers*, 12, 595-606. <https://doi.org/10.1007/s10796-009-9184-x>
- Sleiman, K. A. A., Juanli, L., Lei, H. Z., Rong, W., Yubo, W., Li, S., Cheng, J., & Amin, F. (2023). Factors that impacted mobile-payment adoption in China during the COVID-19 pandemic. *Heliyon*, 9(5). <https://doi.org/10.1016/j.heliyon.2023.e16197>

- Soliman, M., Gulvady, S., Elbaz, A. M., Mosbah, M., & Wahba, M. S. (2024). Robot-delivered tourism and hospitality services: how to evaluate the impact of health and safety considerations on visitors' satisfaction and loyalty? *Tourism and Hospitality Research*, 24(3), 393-409. <https://doi.org/10.1177/14673584231153367>
- Sudaryanto, M. R., Hendrawan, M. A., & Andrian, T. (2023). The Effect of Technology Readiness, Digital Competence, Perceived Usefulness, and Ease of Use on Accounting Students Artificial Intelligence Technology Adoption. E3S Web of Conferences. <https://doi.org/10.1051/e3sconf/202338804055>
- Tannady, H., & Dewi, C. S. (2024). Exploring role of technology performance expectancy, application effort expectancy, perceived risk and perceived cost on digital behavioral intention of GoFood users. *Jurnal Informasi Dan Teknologi*, 80-85. <https://doi.org/10.60083/jidt.v6i1.477>
- Tounekti, O., Ruiz-Martínez, A., & Skarmeta Gomez, A. F. (2022). Research in electronic and mobile payment systems: a bibliometric analysis. *Sustainability*, 14(13), 7661. <https://doi.org/10.3390/su14137661>
- Venkatakrishnan, J., Alagiriswamy, R., & Parayitam, S. (2023). Web design and trust as moderators in the relationship between e-service quality, customer satisfaction and customer loyalty. *The TQM Journal*, 35(8), 2455-2484. <https://doi.org/10.1108/TQM-10-2022-0298>
- Verkijika, S. F., & Neneh, B. N. (2021). Standing up for or against: A text-mining study on the recommendation of mobile payment apps. *Journal of Retailing and Consumer Services*, 63, 102743. <https://doi.org/10.1016/j.jretconser.2021.102743>
- Waheed, M., & Jam, F. A. (2010). Teacher's intention to accept online education: Extended TAM model. *Interdisciplinary Journal of Contemporary Research in Business*, 2(5), 330-344. <https://www.researchgate.net/profile/Mehwish-Waheed/publication/291769213>
- Wais, J. S., & Clemons, E. K. (2008). Understanding and implementing mobile social advertising. *International Journal of Mobile Marketing*, 3(1). <https://openurl.ebsco.com/EPDB%3Aagcd%3A16%3A27764208/detailv2?sid=ebsco%3Aplink%3Ascholar&id=ebsco%3Aagcd%3A32816439&crl=c>
- Wang, F. (2022). The Necessity of Strategic Transformation of Real Estate Digital Operations from the Perspective of Information Economic Management. *Cuadernos de Economía*, 45(129), 60-69. <https://cude.es/submit-a-manuscript/index.php/CUDE/article/view/350>
- Wang, F., & Sahid, S. (2024). Validation of the Entrepreneurial Behaviour Scale among Vocational College Students in China, Using Exploratory Factor and Reliability Analysis. *Eurasian Journal of Educational Research*, 110(110), 254-267. <https://ejer.com.tr/manuscript/index.php/journal/article/view/1672>
- Weng, G. S., Zailani, S., Iranmanesh, M., & Hyun, S. S. (2017). Mobile taxi booking application service's continuance usage intention by users. *Transportation Research Part D: Transport and Environment*, 57, 207-216. <https://doi.org/10.1016/j.trd.2017.07.023>
- Wiese, M., & Humbani, M. (2020). Exploring technology readiness for mobile payment app users. *The International Review of Retail, Distribution and Consumer Research*, 30(2), 123-142. <https://doi.org/10.1080/09593969.2019.1626260>

Chinese Mobile Payment Landscape: A Stimulus Organism Response Model Examining Perceived Value, Satisfaction, And Influences On Customer's Willingness On This Technology

- Wilson, N., Keni, K., & Tan, P. H. P. (2021). The role of perceived usefulness and perceived ease-of-use toward satisfaction and trust which influence computer consumers' loyalty in China. *Gadjah Mada International Journal of Business*, 23(3), 262-294. <https://search.informit.org/doi/abs/10.3316/INFORMIT.147511565887487>
- Wu, C., Huang, L. . (2015). The Study on Continuous Usage Intention of Retailers on Mobile Social Media. *China Business and Market* <https://www.cnki.net/kns/defaultresult/index>
- Wu, C., Shi, Y., Arthanari, T., Gao, Y., & Li, X. (2023). Examining the Chinese mobile phone industry in the reverse supply chains. *Computers & Industrial Engineering*, 182, 109407. <https://doi.org/10.1016/j.cie.2023.109407>
- Yang, W., Vatsa, P., Ma, W., & Zheng, H. (2023). Does mobile payment adoption really increase online shopping expenditure in China: A gender-differential analysis. *Economic analysis and policy*, 77, 99-110. <https://doi.org/10.1016/j.eap.2022.11.001>
- Ye, W., Chen, W., & Fortunati, L. (2023). Mobile payment in China: A study from a sociological perspective. *Journal of Communication Inquiry*, 47(3), 222-248. <https://doi.org/10.1177/01968599211052965>
- Yu, J., Lee, H., Ha, I., & Zo, H. (2017). User acceptance of media tablets: An empirical examination of perceived value. *Telematics and informatics*, 34(4), 206-223. <https://doi.org/10.1016/j.tele.2015.11.004>
- Zeithaml, V. A. (1988). Consumer perceptions of price, quality, and value: a means-end model and synthesis of evidence. *Journal of marketing*, 52(3), 2-22. <https://doi.org/10.1177/002224298805200302>
- Zhong, J., & Chen, T. (2023). Antecedents of mobile payment loyalty: An extended perspective of perceived value and information system success model. *Journal of Retailing and Consumer Services*, 72, 103267. <https://doi.org/10.1016/j.jretconser.2023.103267>
- Zhou, T. (2013). An empirical examination of continuance intention of mobile payment services. *Decision support systems*, 54(2), 1085-1091. <https://doi.org/10.1016/j.dss.2012.10.034>

Constructs and Sources	Items	Factor Loadings	Source
Perceived Value (PV)	PV1: I feel that many of my friends are using this mobile payment app, and using this app can enhance <u>ssnocial</u> interaction.	0.806	(<u>Cai</u> , 2017; <u>Jiang</u> , 2021; <u>Li</u> , 2018;
	PV2: I will choose to use a mobile payment app with a larger number of users.	0.842	<u>Liébana-Cabanillas</u> et al., 2020)
	PV3: This mobile payment app can improve the efficiency of my payment.	0.834	
	PV4: I think using this mobile payment app is more convenient than other payment methods.	0.824	
	PV5: Overall, this mobile payment app is valuable to me.	0.805	
	PV6: This mobile payment app is a good value for the money taking into account its quality and benefits.	0.799	
	PV7: I recognize the value of this mobile payment app based on the benefits it provides in relation to its cost.	0.839	
Satisfaction (S) ()	S1: I think using this third-party mobile payment app is the right decision.	0.789	<u>Ashraf</u> et al., 2020;
	S2: After using this mobile payment app, I am satisfied overall.	0.825	<u>Bhattacharjee</u> , 2001;
	S3: I think this mobile payment app brings me pleasure.	0.786	<u>Bhattacharjee</u> , 2001b; <u>Cao</u> et al., 2018; <u>Chiu</u> et al., 2020;
	S4: I think I am pleased with the specific features and functionalities of this mobile payment app.	0.793	<u>Hong</u> et al., 2006; <u>Jiang</u> , 2021; <u>Li</u> ,
	S5: I think I am pleased with reliability and durability of this mobile payment app.	0.821	2018; <u>Oliver</u> , 1980; <u>Wu</u> & <u>Wu</u> , 2019
	S6: I think I am pleased with the overall quality of this mobile payment app.	0.859	2016; <u>Jiang</u> , 2021;
Willingness to Use (WU) (<u>Ji</u> ,	WU1: I would like to use this mobile payment app to pay.	0.789	<u>Junsawang</u> ,
	WU2: In the future, I will gradually increase the frequency of using this mobile payment app.	0.786	2022; <u>Quan</u> et al., 2019;
	WU3: I would recommend this mobile payment app to my family, friends or colleagues.	0.846	<u>Shang</u> & <u>Wu</u> , 2017)
	WU4: I would suggest this mobile payment app to others who might benefit from it.	0.835	
	WU5: I am confident in recommending this mobile payment app to others.	0.827	
	WU6: I am planning to continue using this mobile payment app in the future.	0.823	

Chinese Mobile Payment Landscape: A Stimulus Organism Response Model Examining Perceived Value, Satisfaction, And Influences On Customer's Willingness On This Technology

	WU7: I foresee myself using this mobile payment app on an ongoing basis.	0.793	
Usefulness (U)	U1: This mobile payment allows me to break through time and place restrictions and make payments anytime and anywhere.	0.803	(Bhattacharjee, 2001 ; Davis, 1989 ; Duane et al., 2012 ;
	U2: This mobile payment app saves me the hassle of carrying cash.	0.779	Fu, 2014 ; Li, 2018 ; Wiese & Humbani, 2019)
	U3: This mobile payment app allows me to conduct transfers, payments, shopping, and other activities more conveniently and quickly.	0.831	
	U4: This mobile payment app can help me improve my quality of life.	0.810	
Ease of Use (EU) (EU1: I can use this mobile payment app to make payments proficiently.	0.750	Davis, 1989 ;
	EU2: For me, the use and operation process of this mobile payment app is easy.	0.721	Hong & Slevitch, 2018 ;
	EU3: Using this mobile payment app to complete the transaction and payment is simple and fast.	0.866	Li, 2018 ;))
Service Quality (SQ)	SQ1: The services provided by this mobile payment app are timely and comprehensive.	0.811	(Chen et al., 2023a ; Chen et al., 2023b ;
	SQ2: This mobile payment app can respond to feedback and questions in a timely manner.	0.845	Rahardja et al., 2023)
	SQ3: This mobile payment app provides professional service support.	0.775	
Cost (C) (Jiang, 2021 ; Wu & Wang, 2005)	C1: If using this mobile payment app requires me to spend money to buy a new phone, it is difficult for me to accept.	0.763	
	C2: If using this mobile payment app requires me to spend money on a new SIM card, it is difficult for me to accept.	0.774	
	C3: If using this mobile payment app comes with a functional charge, it is difficult for me to accept.	0.829	
	C4: If using this mobile payment app creates a large data traffic fee, it is difficult for me to accept.	0.819	
	C5: If I use this mobile payment app to increase the transaction fee, it is difficult for me to accept.	0.837	
Social Influence (SI)	SI1: Important people in my life expect me to use this mobile payment app.	0.812	(Baabdullah et al., 2019 ;
	SI2: The country and social media encourage and recommend me to use this mobile payment app.	0.812	Baishya & Samalia, 2020 ;
	SI3: Using this mobile payment app is a trend and I want to be a part of it.	0.814	Jiang, 2021 ;
	SI4: Using this mobile payment app can better communicate and integrate with a specific group and win recognition.	0.789	Oliveira et al., 2016 ; Patil et al., 2020 ;
			Venkatesh et al., 2003 ;

□

SI5: This mobile payment app is supported in everyday scenarios such as shopping, medical care, and transportation. These advantages make me more willing to use mobile payment.	0.804	<u>Venkatesh et al., 2012)</u>
SI6: With the gradual expansion of mobile payment scenarios, the frequency of my use of this payment app gradually increases.	0.829	
SI7: I hope that this mobile payment app can be used in more and richer scenarios in the future.	0.861	
